

The REV Robotics 2m Distance Sensor uses the ST Microelectronics VL53L0X Time-of-Flight (ToF) laser-ranging module to measure distances up to 2m with millimeter resolution.

Unlike other ranging sensors that rely on the intensity of reflected light, this sensor can measure how long it takes for the light to bounce back, the “time of flight.” This results in much more accurate measurements that are independent of the target’s reflectance.

## SPECIFICATIONS

Measurement Range	5 cm – 200 cm
Measurement Resolution	1 mm
Field of View	25°
Laser Type	940 nm (IR) Class 1
Sensor Type	I <sup>2</sup> C
Maximum Bus Frequency	400 kHz
I <sup>2</sup> C Address	0x52
Voltage Range	3.3 V – 5.0 V
Max. Operating Current	40 mA

## APPLICATION INFORMATION

While the REV 2m Distance Sensor produces a significantly more accurate and reliable measurement than other types of ranging sensors, the following tips will help minimize errors.

A major benefit to time-of-flight measurements is that the target’s surface reflectance does not significantly impact the calculated distance. However, the smallest errors and farthest measurements are achieved with more reflective targets. Similarly, larger targets are easier to detect because they fill more of the sensor’s 25° field of view.

Ambient infrared (IR) interference can also affect the measurement distance and quality. The sensor can produce accurate measurements in sunlit environments, but the maximum distance will be reduced. The following table outlines the typical ranging capabilities of the sensor:

Target Reflectance	Indoor	Outdoor (overcast)
White (88%)	200 cm	80 cm
Grey (17%)	80 cm	50 cm

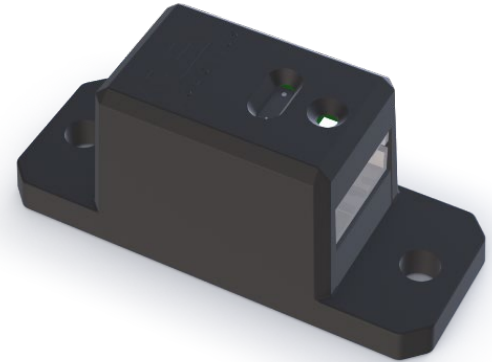

## MECHANICAL DRAWINGS

Caution: Do not touch sensing element. Touching sensor can result in damage

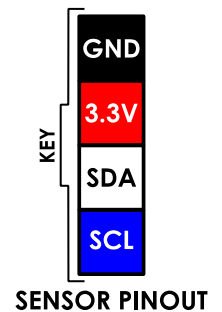
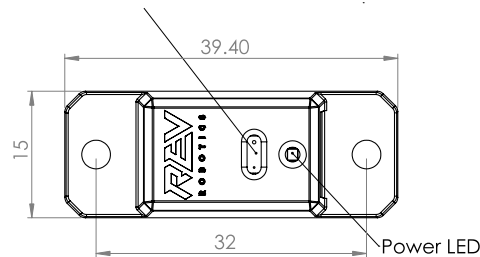

Keep sensor viewing cone free of obstructions.

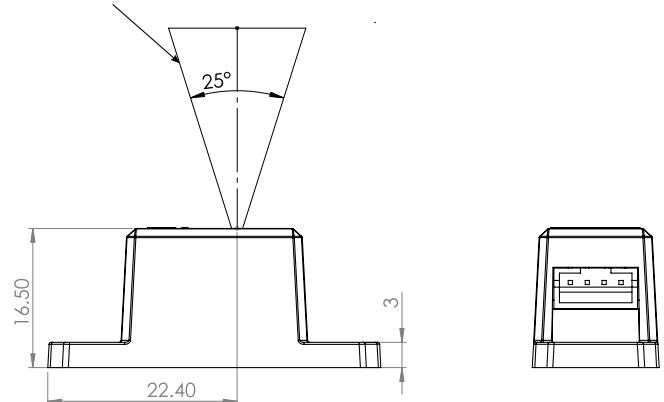

All dimensions are in millimeters.

## ADDITIONAL RESOURCES

Additional information about the VL53L0X, its capabilities, and the ST Application Programming Interface (API) can be found through the ST website:

- [VL53L0X Datasheet](#)
- [VL53L0X API and Documentation](#)