



15MM LINEAR MOTION SYSTEM V2

TABLE OF CONTENTS

1	INTRODUCTION	3
1.1	TOOLS AND MATERIALS	3
2	ASSEMBLY INSTRUCTIONS	4
3	DRIVING LINEAR MOTION	7
3.1	FOUR STAGE CASCADING LIFT	8
3.2	FOUR STAGE CONTINUOUS LIFT	14
3.3	CHAIN LIFT (ADVANCED)	17
4	KIT COMPONENTS (1:1 Scale).....	18

Revision History		
Revision	Date	Description
1	08/10/2018	Initial Release

1 INTRODUCTION

The REV Robotics 15mm Linear Motion kit is designed for use with the REV Robotics 15mm Extrusion. The Linear Motion Kit v2 (REV-45-1507) contains all the necessary hardware (Figure 1) to build a single stage lift. Items necessary for powering the linear motion system are sold separately as part requirements are highly dependent on implementation. This guide is designed to build a three stage lift in two possible configurations (Cascading or Continuous). Additional materials are needed to finish the build and detailed in Section 1.1.

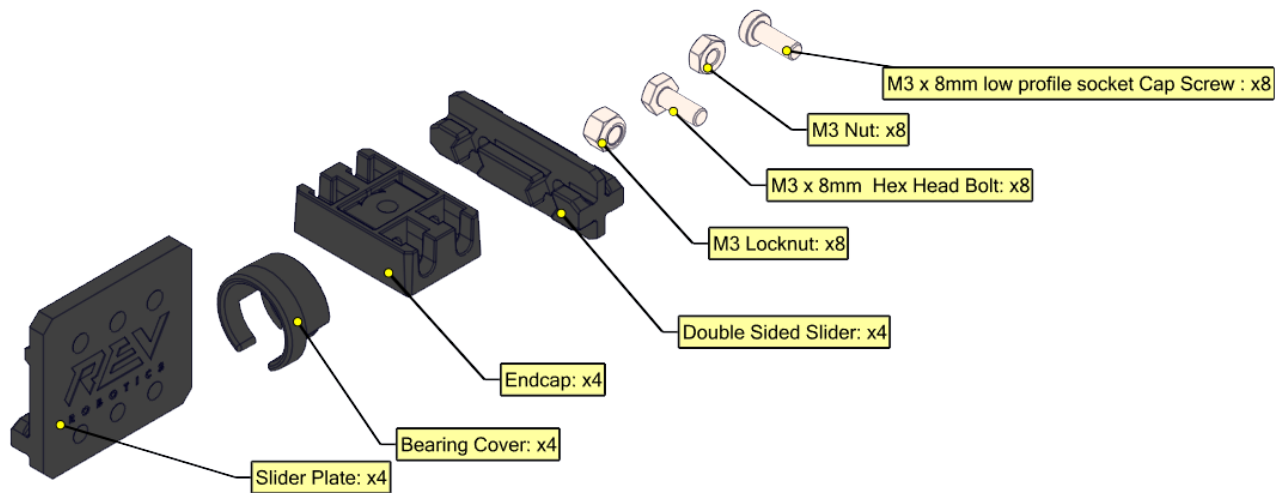

Figure 1: Linear Motion Kit Contents (REV-45-1507)

1.1 TOOLS AND MATERIALS

To complete the full assembly in this guide a few tools and additional materials are needed. Some quantities are depended on the type of lift being built. Check individual sections (3.1 or 3.2) for more information.

For this guide you will need:

- A 5.5mm nut driver
- 2mm Allen Key
- REV Robotics 15mm Extrusion
 - In this example, 420mm lengths are used (REV-41-1432). Different lengths of REV Robotics 15mm Extrusion will work depending on application.
- REV Linear Motion Kit v2 – QTY 2
- Hardware not included in the REV Linear Motion Kit v2
 - Small Pulley Bearings (REV-41-1368) – Max QTY 5
 - M3 x 12mm or longer hex cap bolts (REV-41-1360) – Max QTY 13
 - M3 Nyloc Nuts (REV-41-1361) – Max QTY 13
 - UHMWPE Cord (REV-41-1162) – QTY 1 (actual length is dependent on length of extrusion)
- Core Hex Motor (REV-41-1300) or HD Hex Motor (REV-41-1301) – QTY 1 (this example uses the Core Hex Motor)
- Surgical Tubing

2 ASSEMBLY INSTRUCTIONS

These instructions explain how to build **one half of a single stage lift**. Each linear motion kit contains enough hardware to create a full single stage lift. Repeat this process four times to create all of the segments needed for the four-stage lift.

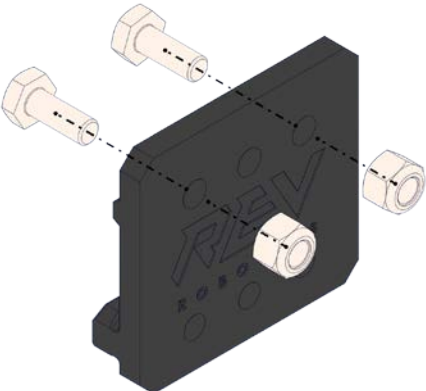
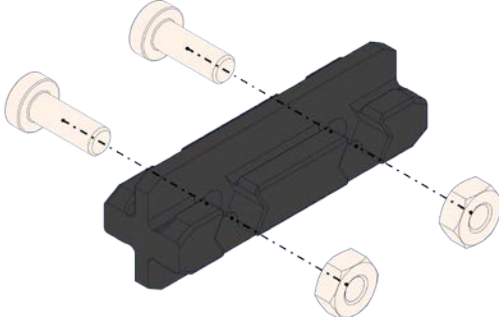
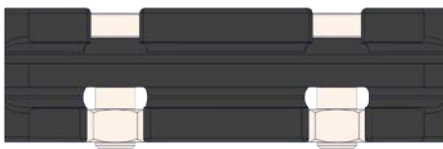
	<p style="text-align: center;">Step 1</p> <p>Insert 2 M3 x 8mm bolts into the holes on the side of the slider plate with just the alignment groove, not the slider. Do not fully tighten these bolts, just start the lock nuts enough so they won't fall off, but leave the bolts loose. Make 2 of these assemblies.</p> <p>Note: use nylock nuts for this application</p>
	<p style="text-align: center;">Step 2</p> <p>Insert 2 M3 x 8mm low profile button head bolts into the double-sided slider. Be sure that you insert the bolts from the correct side because the double-side slider is not completely symmetrical. The bolt head is placed on the side with the circular countersunk cutouts, and the nuts fit into the hex countersunk cutouts. Make 2 of these assemblies.</p> <p>Note: use regular nuts for this application</p>
	<p style="text-align: center;">Step 3</p> <p>When assembling the double-sided slider, only tighten the nut so that it is flush with the bottom of the slider when the bolt head is all the way down. There should be clearance between the top of the nut and the slider as shown.</p>



Step 4

Insert the double-sided slider into the extrusion channel with the nuts in the channel. You may have to slightly loosen or tighten the nut so that it will align with the channel.

Once the slider is fully inserted into the channel, tighten the bolt until snug. **Do not overtighten the bolts as it may cause the slider to deform and bind with the extrusion.**

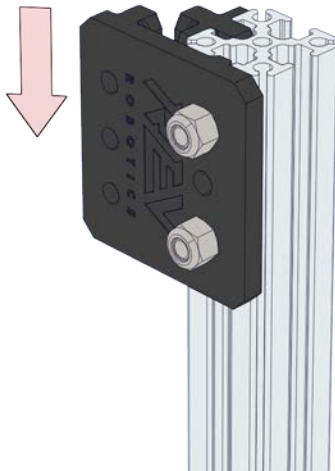

Step 5

Take the slider plate assembly from Step 1 and slide it into the extrusion channel adjacent to the double-sided slider.

Once the slider assembly from Step 1 is fully inserted into the channel, tighten just enough so that the slider plate assembly does not freely slide in the channel, but is still loose enough that you can move the slider with minimal force.

The above steps 1-5 will result in the Basic Assembly for a 15mm linear motion elevator using the REV Robotics Linear Motion Kit and Extrusion (Figure 2). **Repeat the steps 1-5** above four times building the four-stage lift in this guide. A minimum of two assemblies are needed for a single stage lift. Adding additional Basic Assemblies will add more stages to the lift system.



Figure 2: Basic Assembly (Steps 1-5)

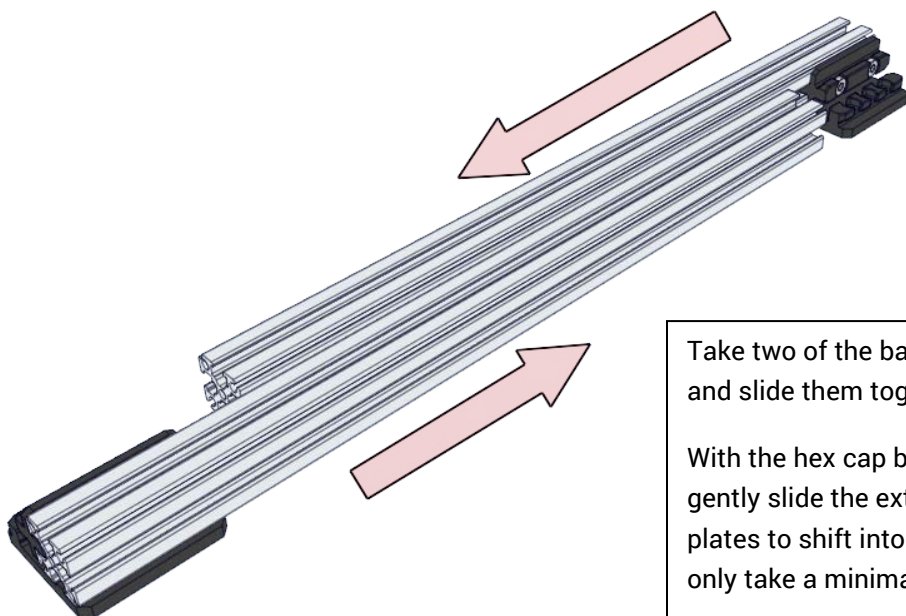

Figure 3: Basic Slide Assembly

Take two of the basic assemblies created in Steps 1-5 and slide them together.

With the hex cap bolts still slightly loose from step 5, gently slide the extrusion in and out allowing the slider plates to shift into optimal alignment. The slide should only take a minimal effort to move.

Carefully tighten the hex cap bolts without shifting the joining plates and re-check the slide for any binding. Repeat as necessary.

To finish assembly for the three stage lift, add two additional basic assemblies to the Basic Slide Assembly shown in Figure 3. One basic assembly is added to each side of the Basic Slide Assembly.

Don't overtighten the bolts as it may cause deformation of the slider plate and binding.

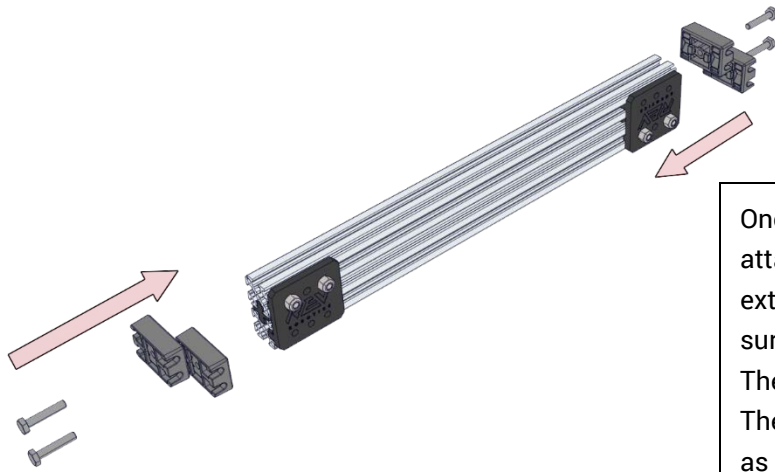

Once all four basic assemblies are slid together, attach an endcap onto one of the ends of the extrusion pieces with a M3 x 8mm or larger bolt. Make sure it is the same end for all four sections of the lift. The ends of the extrusion need to be tapped* for M3. These will help keep the lift from overextending as well as hold the pulleys that are used to drive the lift up and down. Which type of elevator you are making will determine which pieces of extrusion on the lift require an endcap, and which can be left uncovered.

**Tapping will make the attachment easier but is not necessary. Using a M3 x 16mm bolt and nut driver, carefully thread into the end of the extrusion. Finish threading with the nut wrench for addition leverage on the bolt.*

3 DRIVING LINEAR MOTION

Linear motion stages can be driven many different ways, but our recommendation is to use a string wound around a pulley and segments of surgical tubing to operate as a powered return. The string and pulley arrangement is used in one of two ways: Cascading or Continuous lifts. In the Cascading lift assembly, all the stages move up simultaneously, each one by an equal amount. In the Continuous string assembly only one stage moves at a time and the position of each stage relative to each other is not controlled, only the position of the final stage relative to the start position is controlled. This distinction is not relevant in most applications; however, it is a feature that can be used to great effect and is worth keep in mind during design and prototyping. The parts necessary for powering the linear motion system are sold separately as part requirements are highly dependent on the implementation of the lift. The guide **assumes** you are attaching the lift to a robot. For creating this guide REV used a test stand to secure the lift and motor. This stand is shown in the steps for the Cascading and Continuous lift.

To drive the linear motion system, we recommend using a combination of these products:

- Small Pulley Bearings (REV-41-1368)
- M3 x 12mm or longer hex cap bolts (REV-41-1360)
- M3 Nyloc Nuts (REV-41-1361)
- M3 Plain Nuts (REV-41-1126)
- UHMWPE Cord (REV-41-1162)
- Core Hex Motor (REV-41-1300) or HD Hex Motor (REV-41-1301)
- Surgical Tubing

3.1 THREE STAGE CASCADING LIFT

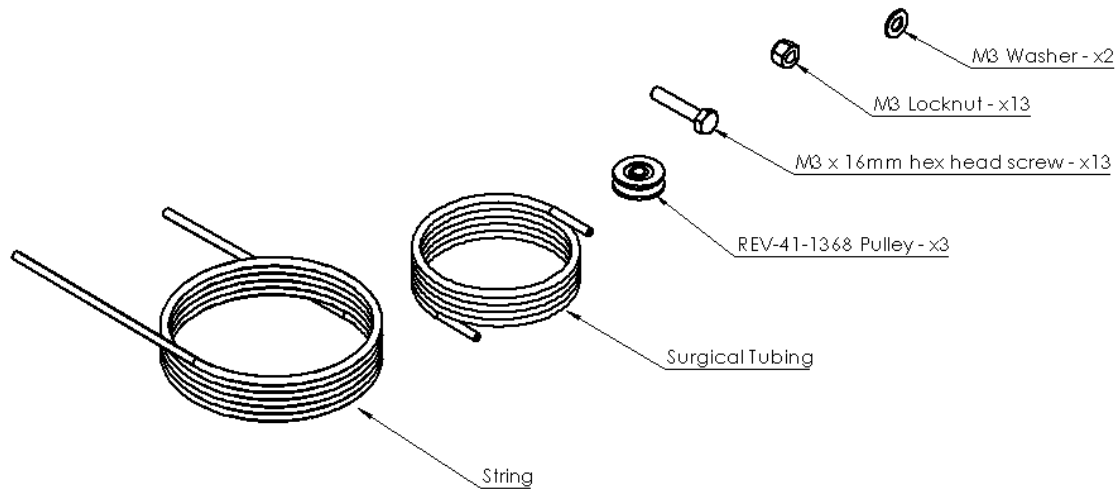

Collect parts and tools for Cascading string assembly, see section 1.1 for details. This guide builds a four-stage lift with a surgical tubing return. These parts are not included in the linear motion kit. You will also need the completed Basic Slide Assembly.

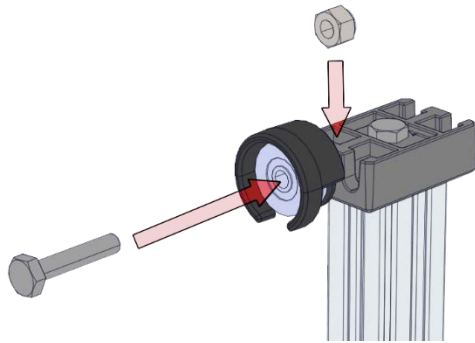

STEP 1

Drop the locknut into the slot on the top of the endcap. Slide the bolt through the pulley, pulley cover, and the endcap. Thread the bolt into the locknut and make sure you thread far enough into the endcap to have the end of the bolt supported by the endcap. This will act as a cantilever support and add strength to the pulley axle when it is under load.

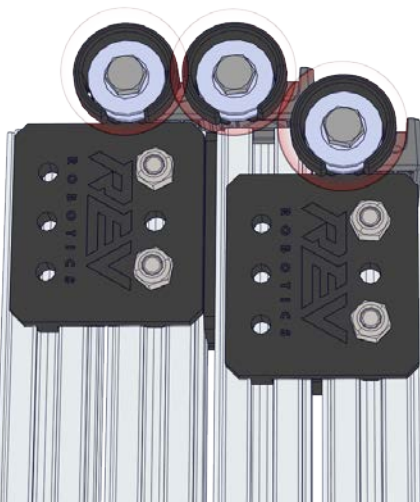

STEP 2

Add a pulley to the top of the first three extrusions. All pulleys must be on the same side of the assembled linear motion system.

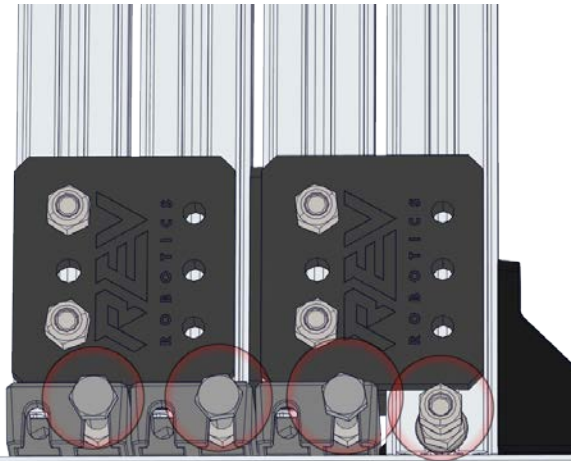

STEP 3

Repeat the previous step for the bottom of the last three extrusion pieces, but don't add the pulley or the pulley cover.

On the bottom of the first piece of extrusion, add a M3 x 16mm bolt and locknut by sliding the bolt into the extrusion channel. Secure it into place.

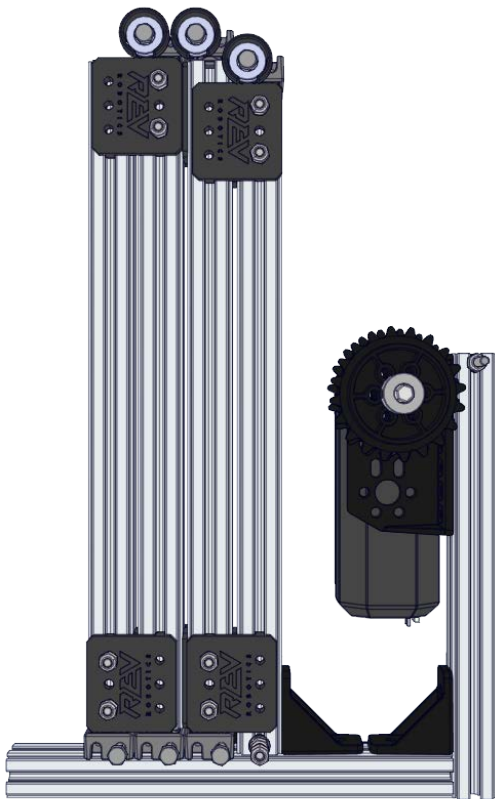

STEP 4

Assemble Lift by securely attaching the stationary first stage extrusion to the frame of your robot using REV plastic or metal brackets.

Position a motor on the side next to the extrusion mounted to the frame.

Note: The motor needs a winding spool attached to it. Attachment of the pulley will vary depending on motor type. In this example, the REV Core Hex Motor has a 5mm Hex shaft with a spool held in place with a pair of shaft collars.

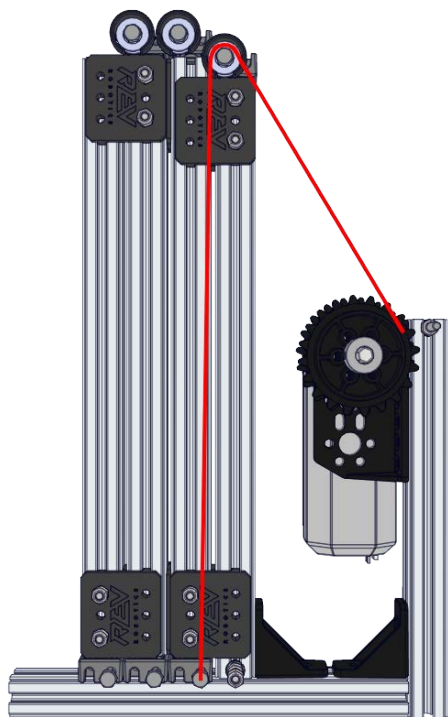

STEP 5

Attach a length of string to the bolt post on the bottom of second stage. Run the string over the pulley at the top of the first stage and down to the winding spool. Secure the string onto the winding spool.

The line may be hard to get onto the pulley with the pulley cover attached, but it is not impossible.

An easier but more time-consuming alternative to get the line onto the pulley is to remove the pulley axle bolt and slip the pulley out from inside the pulley cover. Attach the line around the pulley and slide it back into the pulley cover and reinsert the bolt and tighten.

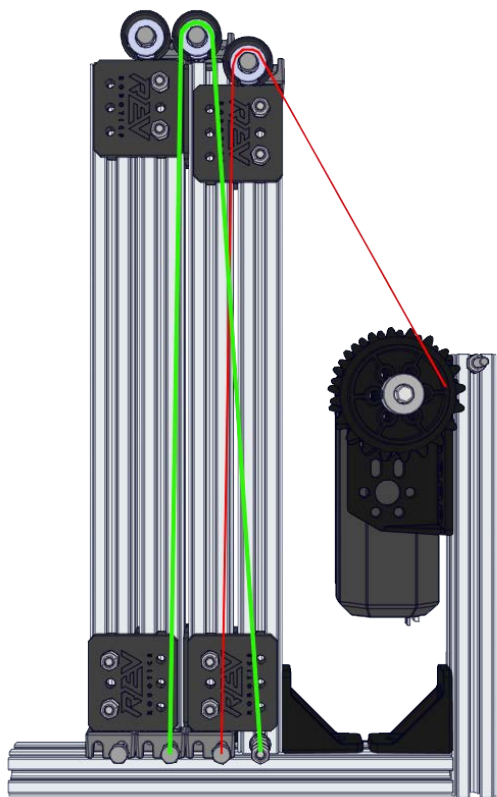

STEP 6

Attach a length of string to the bolt post on the bottom of first stage. Run the string over the pulley at the top of the second stage. Attach the string to the bolt post at the bottom of the third stage.

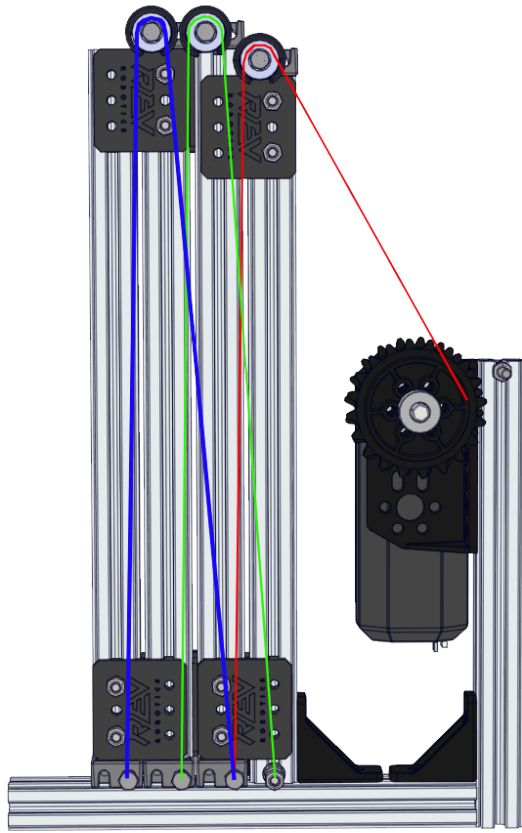

STEP 7

Attach a length of string to the bolt post on the bottom of second stage. Run the string over the pulley at the top of the third stage. Attach the string to the bolt post at the bottom of the fourth stage.

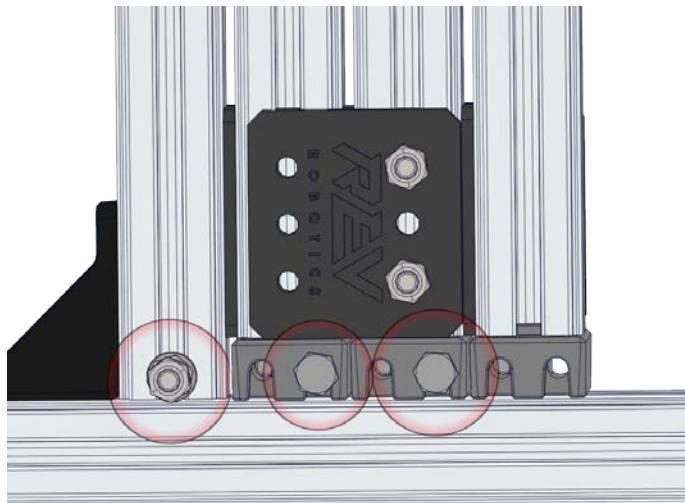

STEP 8

To set up the surgical tubing return system, add bolts on the back side of the endcaps from where you just attached the drive lines. The bolts will mount just like the anchor bolts for the drive lines you mounted earlier in Step 3. Mount one at the base of the first piece of extrusion, and two more in each of the first two end caps.

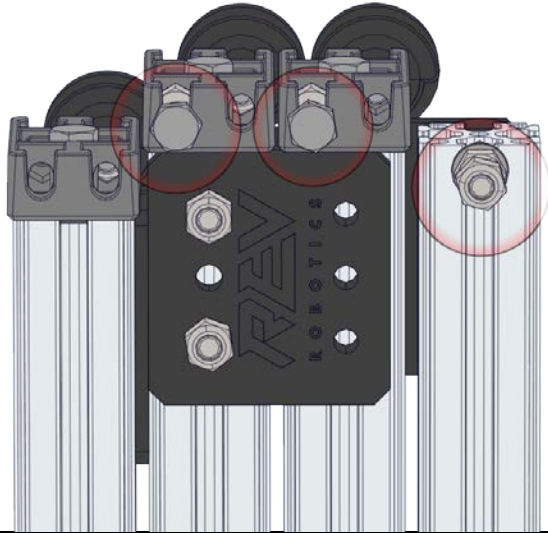

STEP 9

Add bolts to the second and third endcaps like the last step, and a third at the top of the last stage, similarly to the last step as well.

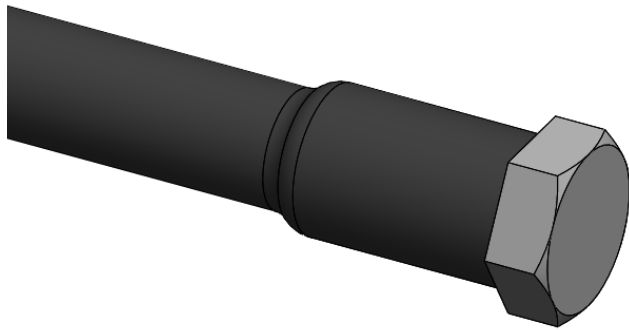

STEP 10

Push a screw into an end of the surgical tubing.

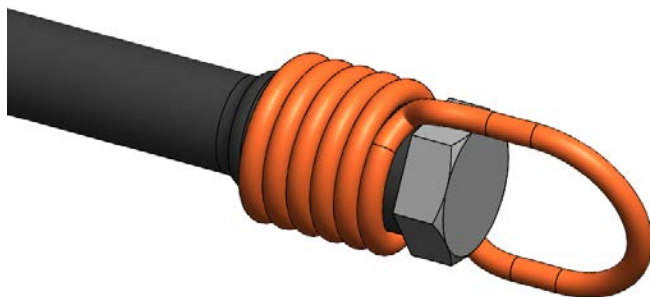

STEP 11

With string tightly wrap the surgical tubing onto the screw and tie it off. Then tie a loop of string such that the loop can be hooked over a screw post.

**alternatively, you can simply tie an end loop knot in the end of the surgical tubing.*

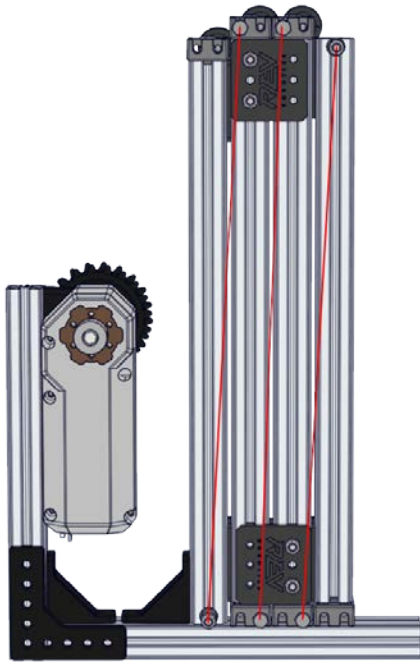

STEP 12

On the back side of the lift, opposite the drive lines, attach 3 surgical tube lengths to the anchor bolts in the end caps in an arrangement seen left.

Adjust the length of each piece to adjust the force that pulls the lift down. For a starting point, the surgical tubing should be just slightly in tension when the lift is in the closed position.

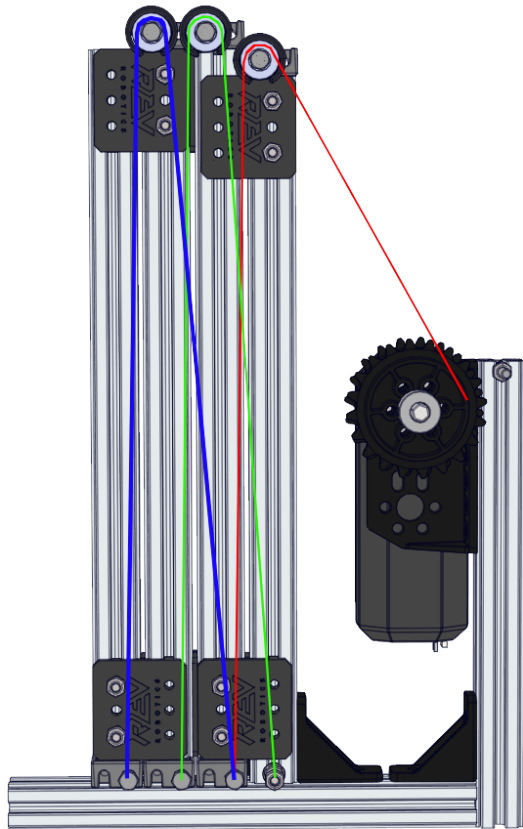

Done!

3.2 THREE STAGE CONTINUOUS LIFT

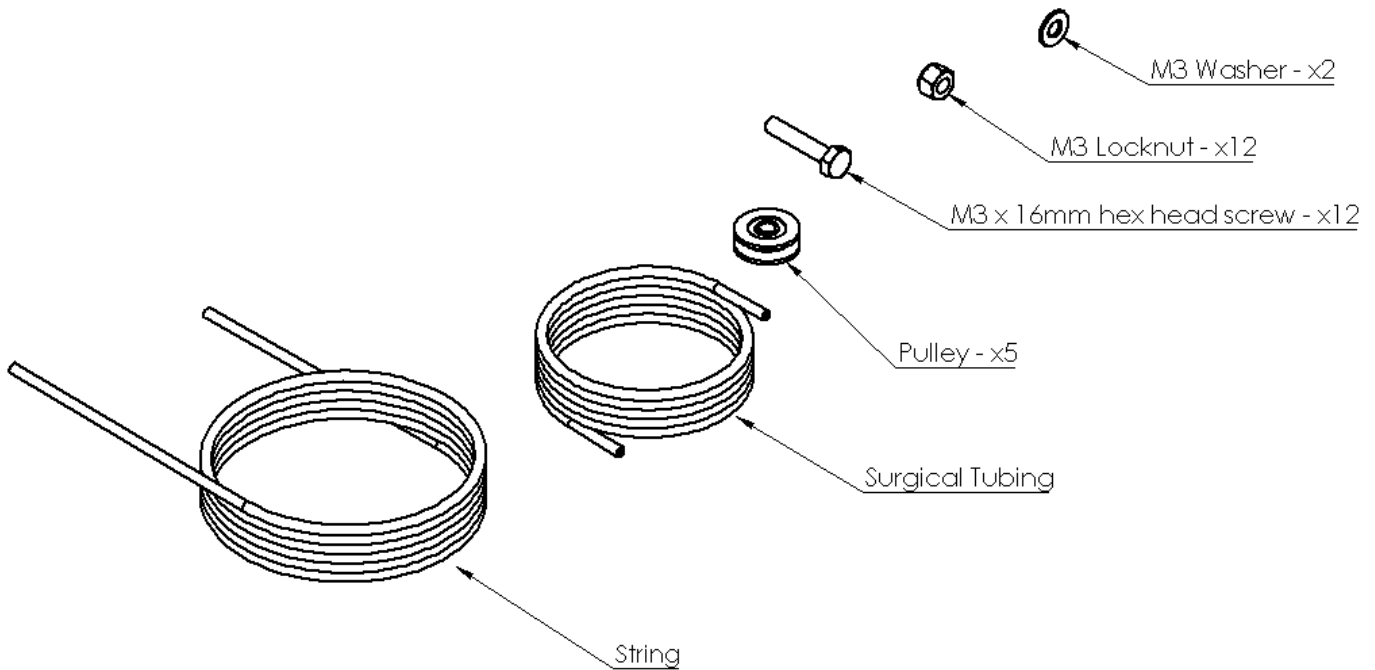

Collect parts for Continuous String assembly. This guide assumes you are building a four-stage lift with a surgical tubing return. These parts are not included in the linear motion kit.

<p>A diagram showing a pulley being assembled onto a linear motion system. A bolt is inserted through the pulley, a pulley cover, and an endcap. A locknut is then placed on top of the endcap. Red arrows indicate the direction of assembly.</p>	<p>STEP 1</p> <p>Drop the locknut into the slot on the top of the endcap. Slide the bolt through the pulley, pulley cover, and the endcap. Thread the bolt into the locknut and make sure you thread far enough into the endcap to have the end of the bolt supported by the endcap. This will act as a cantilever support and add strength in bending to the pulley axle when it is under load.</p>
<p>A diagram showing a linear motion system with three stages. Red circles highlight the pulleys being added to the top of the first three extrusions and the bottom of the two center stages.</p>	<p>STEP 2</p> <p>Add a pulley to the top of the first three extrusions and the bottom of the two center stages. All pulleys must be on the same side of the assembled linear motion system.</p>

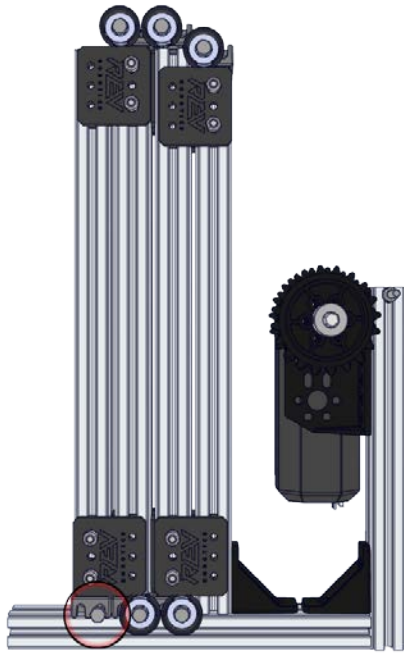

STEP 3

Add a screw post to the bottom of the last stage. The screw post must be on the same side of the assembled linear motion system as the pulley. Attach lift securely to robot frame using our metal or plastic brackets

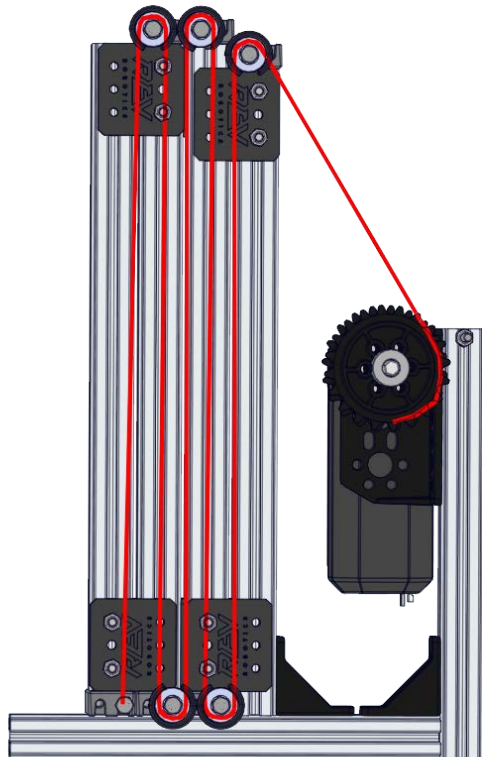

STEP 4

Secure the string onto the winding pulley. Run the string over the pulley at the top of the first stage and down to the pulley on second stage. Then back up to the pulley on the top of second stage. The string then goes down to the pulley on third stage. Then back up to the pulley on the top of third stage. The string then goes down to the screw post on the last stage.

The line may be hard to get onto the pulley with the pulley cover attached, but it is not impossible. An easier but more time-consuming alternative to get the line onto the pulley is to remove the pulley axle bolt and slip the pulley out from inside the pulley cover. Attach the line around the pulley and slide it back into the pulley cover and reinsert the bolt and tighten.

Note: The motor needs a winding pulley attached to it. Attachment of the pulley will vary depending on motor type. In this example, the REV Core Hex Motor has a 5mm Hex shaft with a pulley held in place with a pair of shaft collars.

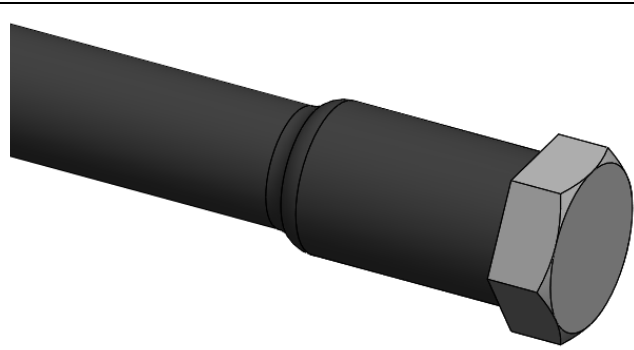

STEP 5

Push a screw into an end of the surgical tubing.

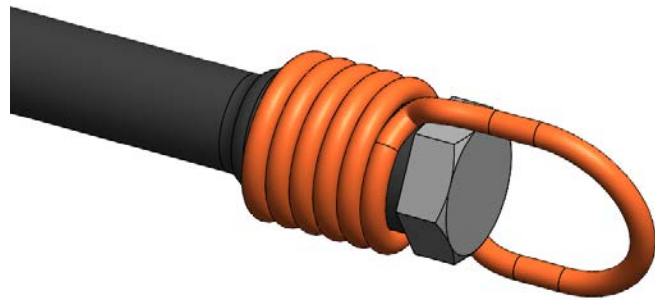

STEP 6

With string tightly wrap the surgical tubing onto the screw and tie it off. Then tie a loop of string such that the loop can be hooked over a screw post.

**alternatively, you can simply tie an end loop knot in the end of the surgical tubing.*

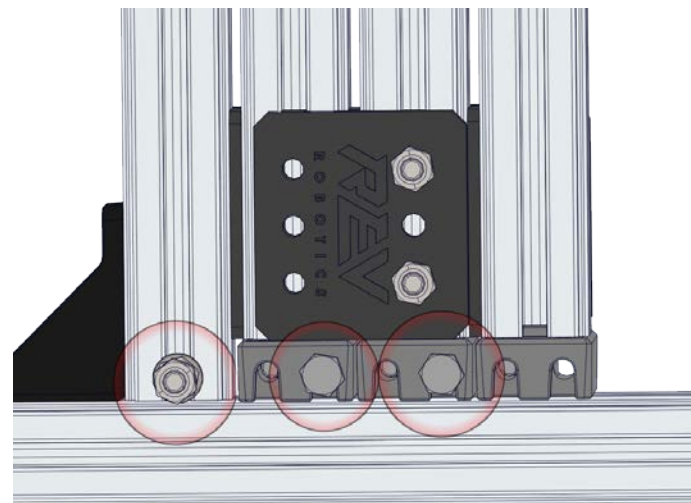

STEP 7

To set up the surgical tubing return system, add bolts on the back side of the endcaps from where you just attached the drive lines. The bolts will mount just like the anchor bolts for the drive lines you mounted earlier. Mount one at the base of the first piece of extrusion, and two more in each of the first two end caps.

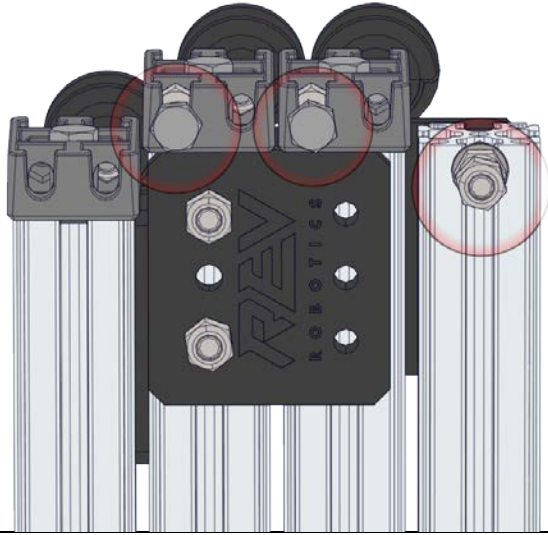

STEP 8

Add bolts to the second and third endcaps like the last step, and a third at the top of the last stage, similarly to the last step as well.

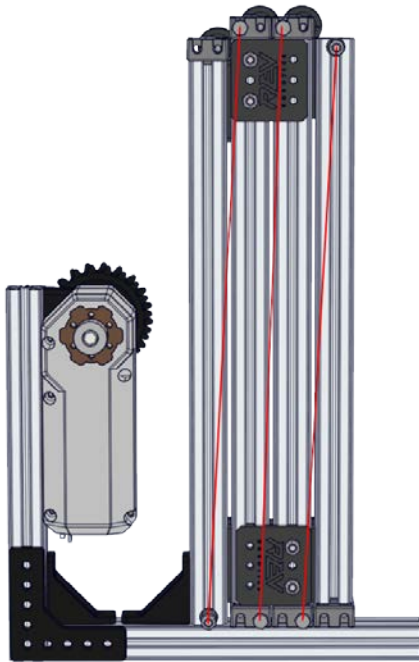

STEP 9

On the back side of the lift, opposite the drive line, attach 3 surgical tube lengths to the anchor bolts in the end caps in an arrangement seen left.

Adjust the tension in each piece to adjust the force that pulls the lift down.

3.3 CHAIN LIFT (ADVANCED)

Chain based lifts are conceptually the same as the continuous string lift. The chain loops back and forth along the stages of the lift and is fixed to the final stage of the lift. The remainder of the chain then loops back to the drive sprocket completing the loop. Interferences and misalignments that a string-based lift is able to tolerate cannot generally be tolerated by chain-based lift. It should be noted that in order to properly tension a chain drive lift a spring-loaded chain tensioner should be used. If a spring-loaded chain tensioner cannot be used the chain must remain vertical or horizontal during operation minimize sine/cosine error stack ups. Given these complexities of implementation a Chain lift should only be used if a team has the expertise to execute and time to properly debug the lift.

4 KIT COMPONENTS (1:1 Scale)



M3 x 8mm Low Profile Socket Cap Bolt – x8



M3 x 8mm Hex Cap Bolt – x8



M3 Nut – x8



M3 Locknut – x8

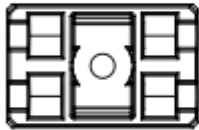

REV-41-1511: Endcap – x4



REV-41-1512: Pulley Cover – x4



REV-41-1519: Slider Plate – x4



REV-41-1520: Double Sided Slider – x4